

tineco

Instruction Manual
Mode d'Emploi

PURE ONE S12 

Smart Vacuum Cleaner

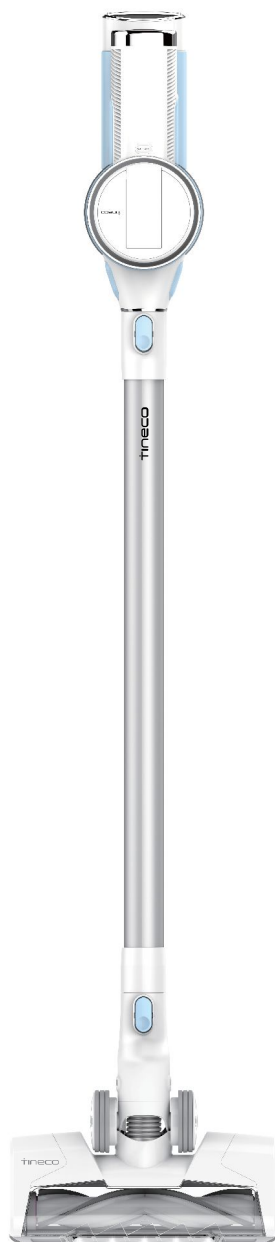

CONTENTS

1.Important Safety Instructions	01
2.Overview	04
3.Product Components	05
4.Accessory Instructions	06
5.Assembly	08
6.Product Operation	10
7.Daily Maintenance	19
8.Specification	22
9.Troubleshooting	23
10.Warranty	25

Important Safety Instructions

SAVE THESE INSTRUCTIONS

Household use only.

When using an electrical appliance, basic precautions should always be followed, including the following:

READ ALL INSTRUCTIONS BEFORE USING (THIS APPLIANCE), Failure to follow the warnings and instructions may result in electric shock, fire and/or serious injury.

WARNING—To reduce the risk of fire, electric shock, or injury:

1. This appliance can be used by children aged from 8 years and above and persons with reduced physical, sensory or mental capabilities or lack of experience and knowledge if they have been given supervision or instruction concerning use of the appliance in a safe way and understand the hazards involved. Children shall not play with the appliance. Cleaning and user maintenance shall not be made by children without supervision.
2. For **INDOOR** use **ONLY**. Do not use the appliance in outdoors, nor in commercial or industrial environments. Do not use the appliance on wet surfaces or surfaces with standing water.
3. Do not allow to be used as a toy. Close attention is necessary when used by or near children, pets or plants.
4. Use only as described in this manual. Use only manufacturer's recommended attachments.
5. Do not use with damaged cord or plug. If appliance has been dropped, damaged, left outdoors, dropped into water, or is not working as it should, return it to a service center.
6. Do not handle charger, including charger plug, and charger terminals with wet hands.
7. Do not put any object into openings. Do not use with any opening blocked; keep free of dust, lint, hair, and anything that may reduce air flow.
8. Keep hair, loose clothing, fingers, and all parts of body away from openings and moving parts.
9. Use extra care when cleaning on stairs.
10. Do not use to pick up flammable or combustible liquids, such as gasoline, or use in areas where they may be present.
11. Do not pick up anything that is burning or smoking, such as cigarettes, matches, or hot ashes.
12. Do not use without filter.
13. Prevent unintentional starting. Ensure the switch is in the off position before connecting to battery pack, picking up or carrying the appliance. Carrying the appliance with your finger on the switch or energizing appliance that have the switch on invites accidents.
14. Disconnect the battery pack from the appliance before making any adjustments, changing accessories, or storing appliance. Such preventive safety measures reduce the risk of starting the appliance accidentally.
15. For the purposes of recharging the battery, only use the detachable supply unit provided with this appliance. A charger that is suitable for one type of battery pack may create a risk of fire when used with another battery pack.
16. Use appliances only with specifically designated TINECO battery packs. Use of any other battery packs may create a risk of injury and fire.
17. When battery pack is not in use, keep it away from other metal objects, like paper clips, coins, keys, nails, screws or other small metal objects, that can make a connection from one terminal to another. Shorting the battery terminals together may cause burns or a fire.

18. Under abusive conditions, liquid may be ejected from the battery; avoid contact. If contact accidentally occurs, flush with water. If liquid contacts eyes, additionally seek medical help. Liquid ejected from the battery may cause irritation or burns.
19. Do not use a battery pack or appliance that is damaged or modified. Damaged or modified batteries may exhibit unpredictable behavior resulting in fire, explosion or risk of injury.
20. Do not expose a battery pack or appliance to fire or excessive temperature. Exposure to fire or temperature above 266°F (130°C) may cause explosion.
21. Follow all charging instructions and do not charge the battery pack or appliance outside of the temperature range specified in the instructions. Charging improperly or at temperatures outside of the specified range may damage the battery and increase the risk of fire.
22. Have servicing performed by a qualified repair person using only identical replacement parts. This will ensure that the safety of the product is maintained.
23. This appliance contains battery cells that are non-replaceable. Do not modify or attempt to repair the appliance or the battery pack except as indicated in the instructions for use and care.
24. Always turn off this appliance before connecting or disconnecting motorized nozzle.
25. Do not charge or store the appliance outdoors or inside the car. Only charge, store or use the battery in a dry indoor area where the temperature is higher than 39.2°F (4°C) but lower than 104°F (40°C). The charger is for indoor use only.

FCC STATEMENT

1. This device complies with part 15 of the FCC Rules. Operation is subject to the following two conditions:
 - (1) This device may not cause harmful interference.
 - (2) This device must accept any interference received, including interference that may cause undesired operation.
2. Changes or modifications not expressly approved by the party responsible for compliance could void the user's authority to operate the equipment.

Note: This equipment has been tested and found to comply with the limits for a Class B digital device, pursuant to Part 15 of the FCC Rules. These limits are designed to provide reasonable protection against harmful interference in a residential installation.

This equipment generates uses and can radiate radio frequency energy and, if not installed and used in accordance with the instructions, may cause harmful interference to radio communications. However, there is no guarantee that interference will not occur in a particular installation. If this equipment does cause harmful interference to radio or television reception, which can be determined by turning the equipment off and on, the user is encouraged to try to correct the interference by one or more of the following measures:

- (1) Reorient or relocate the receiving antenna.
- (2) Increase the separation between the equipment and receiver.
- (3) Connect the equipment into an outlet on a circuit different from that to which the receiver is connected.
- (4) Consult the dealer or an experienced radio/TV technician for help.

FCC Radiation Exposure Statement

This equipment complies with FCC radiation exposure limits set forth for an uncontrolled environment.

This equipment should be installed and operated with minimum distance 20cm between the radiator & your body.

Note:

The manufacturer is not responsible for any radio or TV interference caused by unauthorized modifications to this equipment, such modifications could void the user's authority to operate this equipment.

The device has been evaluated to meet general RF exposure requirement. The device can be used without restriction.

IC Note

This device complies with Industry Canada RSS standard(s). Operation is subject to the following two conditions:

(1) this device may not cause interference.

(2) this device must accept any interference, including interference that may cause undesired operation of the device.

- This Class B digital apparatus complies with Canadian ICES-003.

The device has been evaluated to meet general RF exposure requirement.





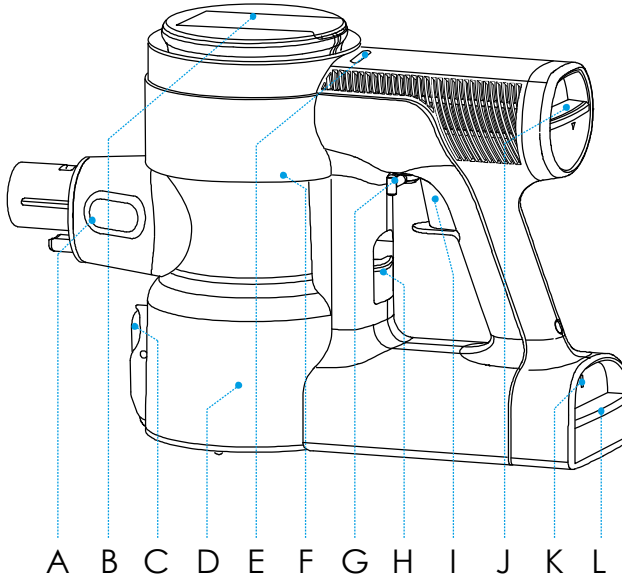





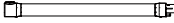

The device can be used without restriction.

Overview

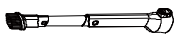

- A. Dust sensor
- B. Phone holder
- C. Dust empty release button
- D. Dustbin
- E. MAX/AUTO button
- F. WiFi reset button (remove dustbin to find the button)
- G. Switch lock
- H. Dustbin release button
- I. Switch button
- J. HEPA release button
- K. Battery indicator light
- L. Battery release button

Product Components

	Item	PURE ONE S12 M
	Main body	○
	Tube	○
	Full-size LED multi-tasker power brush	○
	Mini power brush	○
	2-in-1 dusting brush	○
	Crevice tool	○
	Soft dusting brush	○
	Flexible long crevice tool	○
	Pre-filter cleaning tool + Extra pre-filter	○
	Extra lithium battery	○
	Wall-mounted dock	○
	Dual adaptor	○
	Hair cleaning tool	○

***Actual accessories may vary from shown or change without notice.**

Available accessories may vary by market.

Accessory Instructions

Note:

- **Test an inconspicuous area of a sensitive surface before using an accessory on it.**
- All accessories can be directly connected to the main body or to the tube.

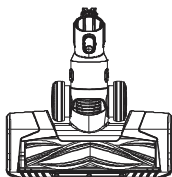

Full-size LED multi-tasker power brush
Ideal for both hard floors and carpets.
Very effective for agitating dirt embedded in the carpet.



Mini power brush
For vacuuming upholstered furniture, mattresses etc.
Vacuums pet hair and removes ingrained dirt.

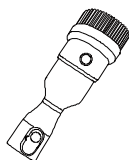

2-in-1 dusting brush
Composed of a wide and a soft brush, and is able to switch from wide brush to soft brush by pressing the release button. Soft brush is for hard surface furniture and the wide brush to vacuum upholstered furniture, curtain, etc.

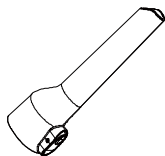

Crevice tool
For corners, niches and other hard-to-reach places, such as car seat and mat, picture frame etc.



Soft dusting brush
Angled bristles on slender, oval shape provide anti-static cushioned contact. Suitable for dusting shelves, lighting, delicate surfaces, electronics, and more.

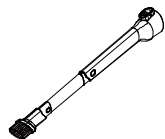

Flexible long crevice tool
Easy to bend, easily gets into the tight spots. Suitable for cleaning dust beneath furniture, along side the refrigerator, around radiators or vents, and more.

Accessory Instructions

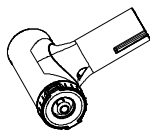

Pre-filter cleaning tool

Dirty filter is a main cause of suction loss, this tool is designed for a deeper & easier cleaning solution with no suction loss. For using this tool, take out the dirty pre-filter from the mesh filter-holder, and replace a clean one. Open the cover of the cleaning tool, put inside the dirty pre-filter and cover it. Connect the tool to the main body. Activate the appliance on MAX mode, and rotate the side cover.



Hair cleaning tool

Use the end with small blade to remove the hair and debris wrapped around the roller. Use the end with little brush to clean the brush window, also can be used to clean the dustbin.

Optional accessories (please purchase separately)

Note: You can purchase additional accessories from TINECO.

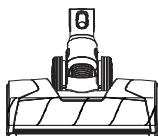

Full-size LED soft-roller power brush

Perfect for hard floors, especially sensitive wood floor. Picks up coarse and fine dirt at the same time.

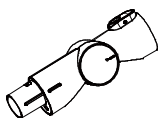

Multi-angle folding tube

One articulated joint makes it adjustable, clean from high to low place with flexibility.



Flexible extension hose

Excellent extension and flexibility to get into hard-to-reach spaces, great for in-car usage. Use with TINECO accessories, except motorized brush.

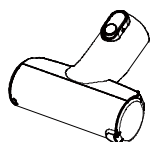

Automatic pre-filter cleaning tool

Dirty filter is a main cause of suction loss, this tool is designed for a deeper & easier cleaning solution with no suction loss. For using this tool, put inside the dirty filter into the cleaning tool and cover it. Connect the tool to the main body and start cleaning. The appliance will automatically shut off in 1 min once finished.

Assembly

Install the Tube

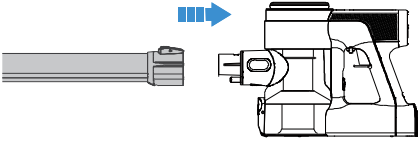

Insert tube.

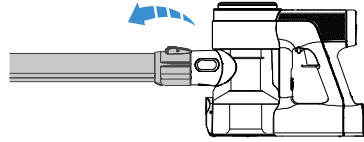

Press the release button and remove tube.

Install the Brush

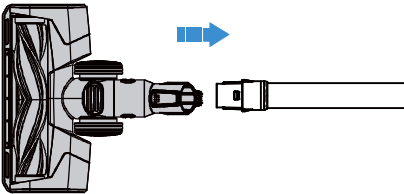

Insert the power brush.

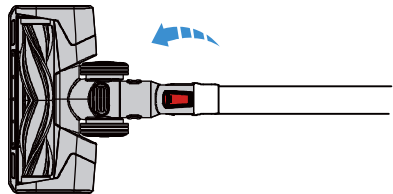

Press the release button and remove power brush.

Assembly

Install the Dustbin

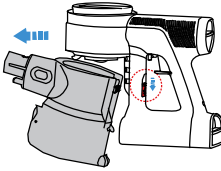

To better clean the dustbin, press the dustbin release button and pull out.

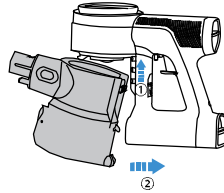

Incline the dustbin, the slot on the dustbin towards the hook on the main body. Push upward until the hook fixed into the slot. A 'click' sound will be heard when it has been successfully accomplished.

Install the Battery

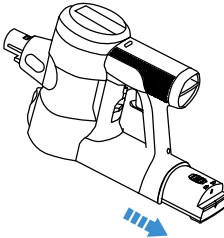

Press the battery release button, then pull the battery out.

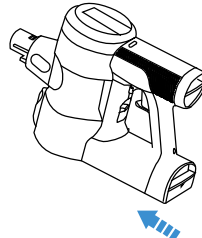

Slide the battery into the bottom of the main body. The battery will click into position when correctly fitted.

Product Operation

Start to Work

Note:

- Before the first use, please charge the appliance (see "Charging the battery") for 3-4 hours in an area where the temperature is higher than 39.2°F (4°C) but lower than 104°F (40°C), and the above charging time based on the condition that the battery is cooled.
- Select the accessories according to needs (see "Accessory Instructions").

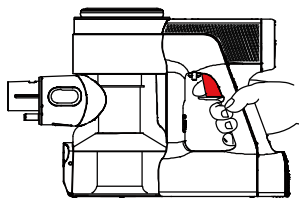

Press the switch button, the appliance will start to work.

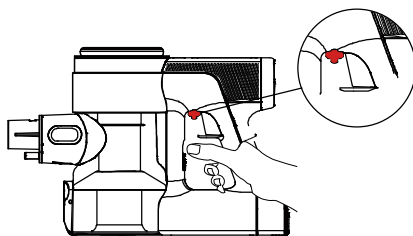

Pull the switch lock for continuous power mode.

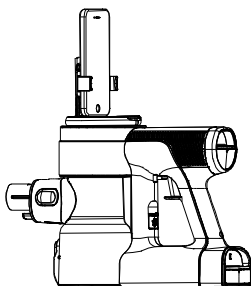

The phone can be cradled firmly on the phone holder.
The appliance is activated in AUTO mode by default.
Press MAX/AUTO button to switch to Max mode.
More functions are available in Tineco App.

Product Operation

- After using the appliance, it is recommended to put it on the wall-mounted dock for recharge and storage.

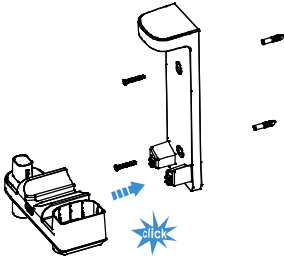

Assemble the two parts of the bracket, a 'click' sound will be heard when it has been successfully accomplished. Then install the wall-mounted dock to the wall with the nails provided by Tineco.

Warning:

- Please make sure there is no gas, water or electrical cables and wires behind the mounting area.
- To avoid the dock dropping down, please make sure it must be installed firmly.

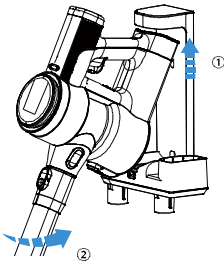

Place the main body on the docking station.

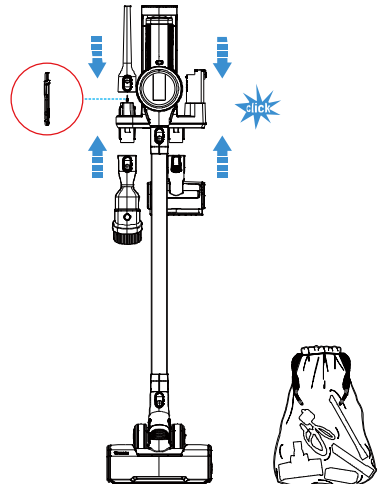

To avoid the deformation of the bristles, always put away the accessories on the docking station after use, a 'click' sound will be heard when it has been successfully accomplished. The rest parts can be stored in the tools bag.

Product Operation

Cleaning Mode Selection

AUTO mode

• In AUTO mode, the power indicator and the color of dust monitoring loop change along with the dust amount. The color change from red to blue as the place getting cleaner. You can get the best cleaning solution automatically.

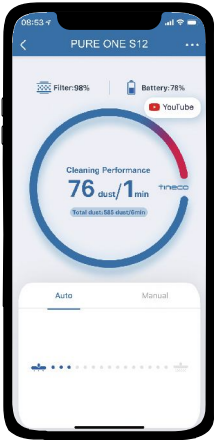

Start in two ways:

①

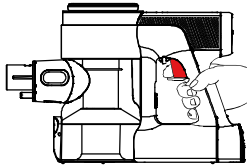

The default setting is AUTO mode after starting up, 3s to check blockage and then detect the amount of dust. If no dust detected, the power is reduced to cruise power.

②

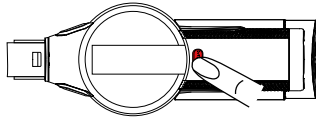

or

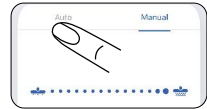

In the Max mode, press MAX/AUTO button or click AUTO in the App to enter the AUTO mode.

Max mode

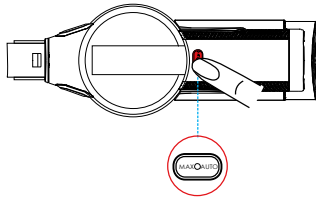
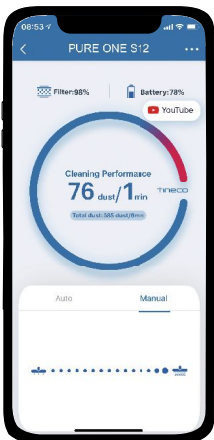

In AUTO mode, press the MAX/AUTO button and switches to Max mode.

In Max mode, the Dust monitor's color will change along with the dust amount as well.

Remark: You can also swipe in the App to adjust suction power as needed.

Product Operation

App User Guide

- All the functions can be performed using the Tineco App. Download Tineco App to access more features.



🔍 Tineco



✔ iOS 8.0 or later

✔ Android 5.0 or later

Download App

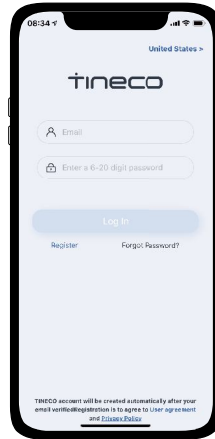

Register and log in

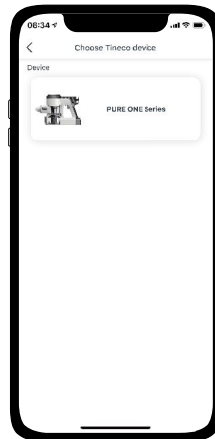

Click "Add a device", select the model and connect to the network.
(iOS users may need to set WiFi network manually.)

Product Operation

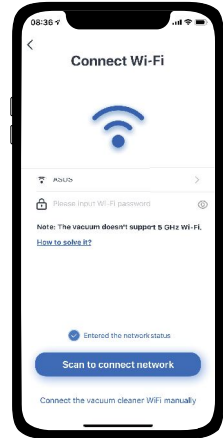
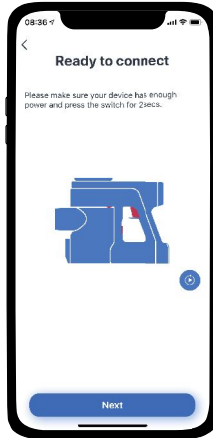
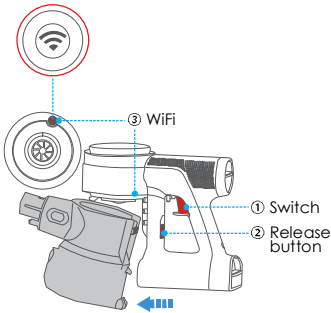

Ensure that the appliance has enough power, press the switch for 2s to activate. Press release button to remove the dustbin, hold WiFi reset button for 2s and wait for connection.

Please choose your network and enter the password for the first connection.



or

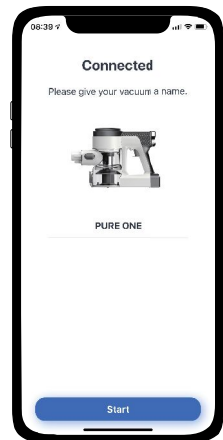

Two ways to connect:

Find a barcode beginning with E at the vacuum's bottom or the package box, align the barcode within frame to scan.

Or connect your phone with the WiFi that starts with "Tineco_xxxx", come back to this App after the connection is completed.

Connected and Start.

Product Operation

App Function Introduction



Battery

Battery level in real time.



Cleaning report

Display the dust amount, working hours and working status.



Suction adjustment

Manual mode, swipe the screen to adjust suction power.



Reminder of filter status

Record the severity of dirty filter and give a cleaning reminder.



Contact us

You can contact the Customer Service about any problems during the working hours.



Feedback

If you have any comments, please send us your feedback in text, picture, or videos.

Note:

- Please keep your hands dry when using it.
- Oil and water stains on your finger may affect screen swiping.

Product Operation

Empty the Dustbin

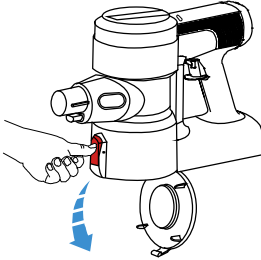

When finished, press the release button on the side of the dustbin and empty the contents.

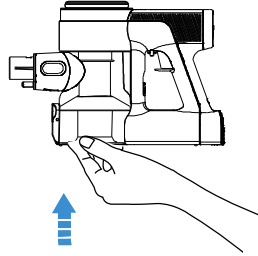

Reattach the dustbin's bottom cover.

Charging the Battery

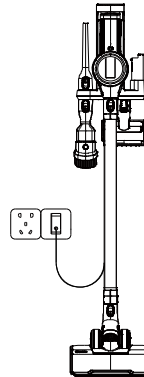
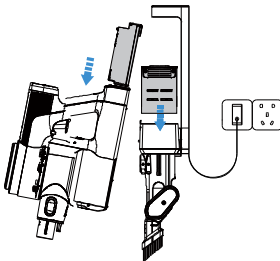

Connect the adaptor to wall-mounted dock and outlet.
Charge the battery installed on the main body, or charge the battery separately.
Dual adaptor can charge two battery packs at the same time.

Warning:

- Charge the unit only with the adaptor from TINECO.
- When you won't use the lithium battery for a long time, please store in a cool dry place. In this situation, please charge the battery every 3 months, and insure that the battery has been at least half charged (Battery level > 50%).
- Store appropriately indoors in a dry place. Do not expose machine to sunlight or freezing temperature. Recommended temperature range: 39.2°F (4 °C)~104°F (40 °C).

Product Operation

Working Time

- Working time last about 40 mins. on AUTO mode, about 9 mins. on MAX mode.
- Data is obtained by Tineco laboratory using one battery and non-motorized accessories.

Charging Time

- A full charge takes about 3-4 hours.
- Based on results from Tineco lab tests. Lab test environment: temperature between 39.2°F (4°C) to 104°F(40°C).

Indicator Light

- If you see the fault lights, please check Troubleshooting.

On Work



Battery level > 20%: Solid green light.



Battery level \leq 20%: Solid red light.



Blinking red light: Fault.



Light up: Working.

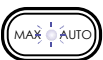

Blinking: Possible reasons are motor failure, air channel blocked, dust sensor defective, brush roller tangled, filter too dirty.

Product Operation

Connect to network



Light up: Successfully connected.



Blinking: Connecting to the network.

During Charging



Charging (Battery level 0%~99%)

Battery indicator: Breathing green light.

MAX/AUTO indicator: Breathing white light.



Fully charged (Battery level up to 100%)

In 5 mins:

Battery indicator: Solid green light.

MAX/AUTO indicator: Solid white light.

5 mins later:

Both indicators off.



Indicator light blinking: Fault.

Daily Maintenance

In order to maintain appliance performance, it is recommended that you clean the components periodically.

Note:

- Clean the dustbin and filters every time after use.
- The HEPA and pre-filter are consumable. Replace them with new ones when the suction performance cannot get back to normal after cleaning.

Dustbin and Filters (mesh filter, pre-filter and HEPA filter)

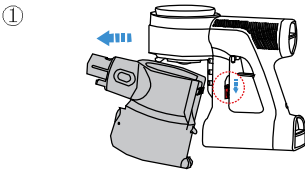

Press the dustbin release button, pull out the dustbin.

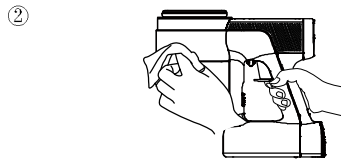

Clean with wet cloth. Do not allow water to enter the appliance, especially not into motor and battery.

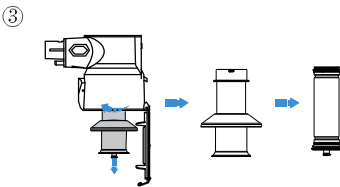

Twist anti-clockwise and remove the filters.

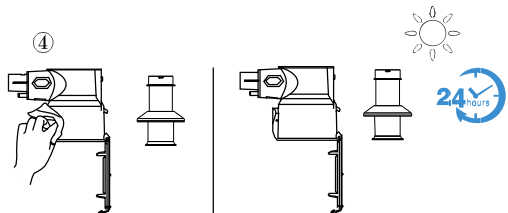

Clean the dustbin and mesh filter with wet cloth. The two parts should be air dried completely before reinstalling.

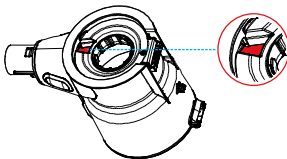

Warning:

- Do not wash the dustbin as there is a dust sensor inserted. Please make it completely dry with a hair dryer if it meets water.

Daily Maintenance

Pre-filter

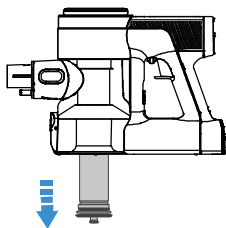

Please turn off the appliance before cleaning and take out the dirty pre-filter from the mesh filter-holder.

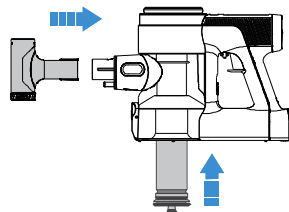
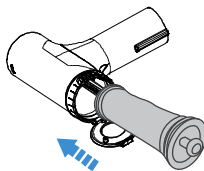

Replace a clean filter to the main body. Put the dirty pre-filter into the cleaning tool and connect the cleaning tool to the main body.

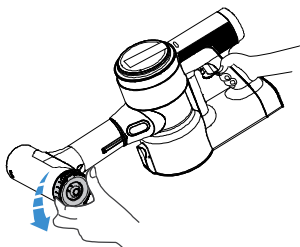

Activate the appliance on MAX mode, and rotate the side cover to clean the dirt pre-filter. Then remove the filter for backup after cleaning.

Daily Maintenance

HEPA filter

In order to maintain appliance performance, it is recommended that you clean the filter periodically.

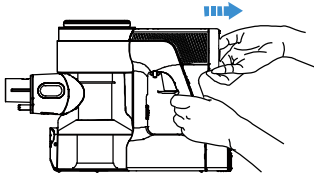

Press the HEPA release button and gently pull out the HEPA to remove the dust.

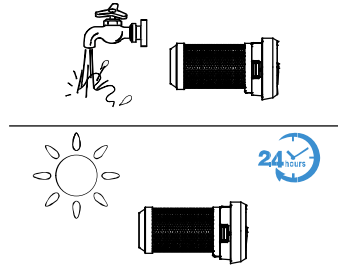

The HEPA can be washed under running water if necessary, and should be dried completely before reinstalling.

Brush

1

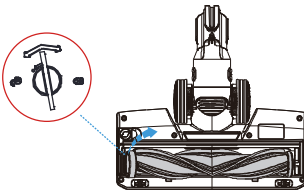

Use a coin or other tool, to unlock the brush roller lock, then remove the brush from the brush window.

2

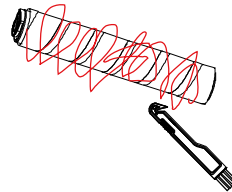

Remove the hair and debris wrapped around the roller with Tineco Hair Cleaning Tool.

3

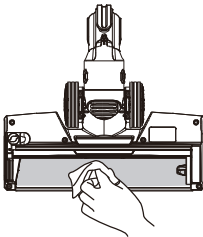

Gently clean the transparent brush window.

4

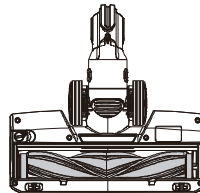

After the cleaning, install the brush into the machine.

Warning:

- The power brush contains electrical components that cannot be soaked or washed with water.

Specification

Model	PURE ONE S12 M
Voltage	21.6V 2000mAh Li-ion
Rated Power	500W
Dustbin Capacity	0.6L
Charging Time	3-4 hrs
Charging Input	100-120V ~
Running Time(Two batteries)	40*2 min. (MAX mode: 9*2 min.)



Disposal

- The battery contains materials that are harmful to the environment and must be removed from the appliance before it is discarded.
- When removing the battery, the appliance must be powered off.
- Waste batteries should be handled properly. Do not put them into fire, water or soil. 
- If the battery leakage touches the skin or clothing, flush with water immediately to avoid skin injury and seek medical help.

Troubleshooting

Problem	Possible cause	Solution
The appliance doesn't work	No power	Charge the battery
	AUTO protection for overheated temperature	Restart after cooling
	The suction mouth is blocked	Check and remove blockages
Weak suction power	Dustbin and filters are full of dust	Clean the dustbin and filters
	The pre-filter is not installed	Install the pre-filter
	The appliance is blocked (such as tube, suction mouth or some other parts)	Remove blockages
	The brush roller is wrapped by hairs or fibers	Clean the brush roller
Abnormal motor sounds	The appliance is blocked (such as tube, suction mouth or some other parts)	Remove blockages
Battery won't charge	The adaptor is not correctly inserted	Reinsert the adaptor correctly
	Poor contact of the main body or battery	Check if the main body and battery are correctly placed
	The adaptor is not designed for PURE ONE S12 M	Use the original adaptor

Troubleshooting

Problem	Possible cause	Solution
Indicator light blinking during charging 	Light off after 6s, charging error	Check if the adaptor and battery are in good condition
	Keep blinking, no battery pack on the main body	Insert the battery on the main body
Indicator light blinking on work 	Motor failure	Remove blockages and restart
	Air channel blocked	Remove blockages
	Brush roller tangled	Clean the brush roller
	Full of dust in filter	Follow Daily Maintenance to clean the filter
	Dust sensor defective	1. Clean the dust on the inner sensor 2. Install the dustbin correctly
Battery indicator blinking red light on work 	Battery failure	Remove the battery pack and cool it down

Note:

In any other case or if the solution explained above did not solve the problem, please contact us at support@tineco.com or visit our website www.tineco.com for further support.

tineco
Live Easy
Enjoy Life



tinecoglobal 



 +1 (855)292-8864 Mon. - Fri. 9am - 6pm (CST)

 Support and Feedback

 Support@tineco.com

 www.tineco.com

Contact us - We'll get back to you within 1 business day.